

# WESTERBEKE 15 KW MARINE DIESEL GENERATOR SET

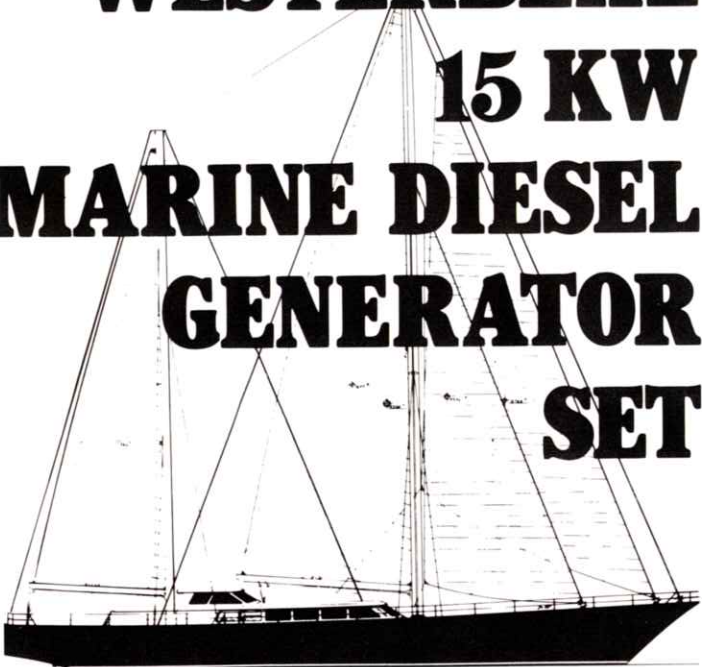

Custom Design by John G. Alden

The smallest, quietest, most advanced generator for all ship-board needs; 120 or 120/240 volt electrical power at the turn of a switch for electric cooking, refrigeration, air conditioning, cabin appliances, power tools, and navigation/communication equipment. Like all Westerbeke generator sets, it is fresh water cooled through an engine-mounted heat exchanger. The complete unit is mounted on lightweight rails through soft flexible isolator mounts to prevent vibration. A lightweight removable drip tray is fitted under the unit between the mounting rails. The engine is equipped with an electric fuel pump and self bleeding fuel system.

The cast iron cylinder head and block, swirl type combustion chamber, and tuned air intake silencer produce unsurpassed quiet running. The BT alternator with its integral flywheel housing, compact brushless construction and built-in transformer regulation, attaches directly to the engine's backplate.

The model 15 BTD is lightweight, safe, dependable, and economical to operate.

*For power or sailboat . . . a new series of compact diesel generator sets from Westerbeke.*

## New for 1987 — 15KW compact brushless diesel generator set of the BTD Series

- **SMALLEST AVAILABLE AND OVERLOAD CAPACITY TOO!**
- **ENCLOSED FRESH WATER COOLING**
- **AUTOMATIC SAFETY SHUT-DOWN**
- **SIMPLE ENGINE AND GENERATOR CONTROLS FOR RELIABILITY**

### STANDARD EQUIPMENT

- 12 Volt 50 Ampere Alternator
- Coolant Recovery Tank
- Fresh Water Cooling
- Operators Manual
- Vibration Isolators
- Control Panel
- Water Injected Exhaust Elbow
- Drip Tray
- Belt Guard
- Air Intake Silencer
- 12 Volt Start Motor
- High Water Temp. Low Oil Pressure
- High Exh. Temp. Auto Shutdown

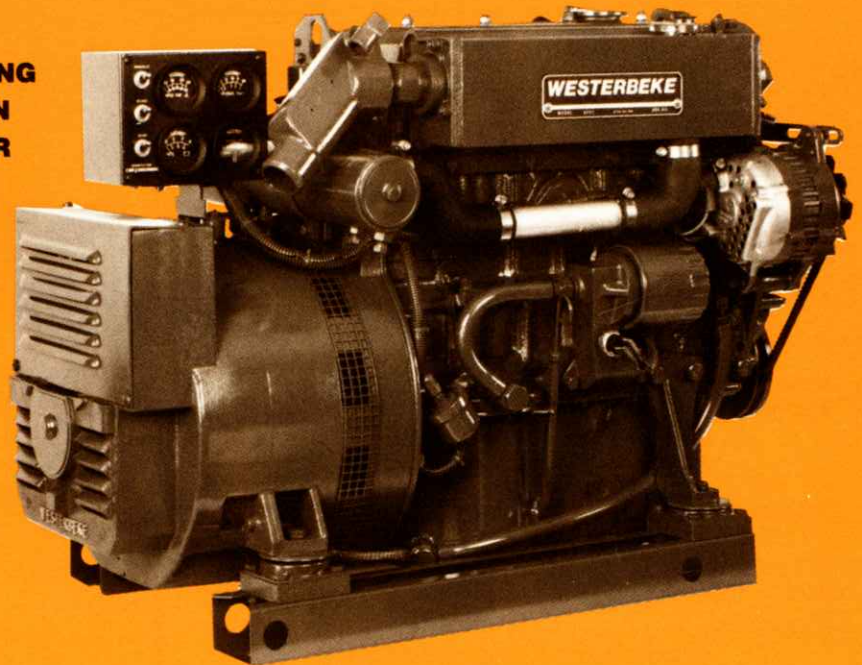

**GENERATORS: 3, 4.4, 6, 8, 8g, 11, 12.5, 15, 20, 25, 32, 45 kw's**

**Fresh Water Cooled Diesel and Gasoline Generators from Westerbeke.**

# WESTERBEKE 15KW MARINE DIESEL GENERATOR

## RECONNECTABLE BRUSHLESS ALTERNATORS

MODEL	ELECTRICAL CHARACTERISTICS				RATINGS		ENGINE	
	VOLTS	AMPS	HERTZ	PHASE	WIRE	1.0 POWER FACTOR	RPM	START
15 BTD-614	120/240	125/62.5	60	1	4	15KW	1800	Remote
15 BTD-634	120/240*	36	60	3	4	15KW	1800	Remote
12 BTD-514	220	120/60	50	1	4	12KW	1500	Remote
12 BTD-534	220/380*	34.5	50	3	4	12KW	1500	Remote

**WESTERBEKE 15 KW**

**DESIGN:** Brushless, four pole, revolving field, self regulating, pre-lubricated single bearing design. (Optional full power take-off through rear of generator available.)

**VOLTAGE REGULATION:** Standard  $\pm 5\%$  no load to full load. (With optional solid state voltage regulation  $\pm 2\%$  no load to full load.)

**FREQUENCY REGULATION:** 3 Hertz (5%) no load to full load. (Generator is capable of operation at either 50 or 60 Hertz by simple adjustments.)

**INSULATION:** Class "F" as defined by NEMA MG1-1.65.  
**TEMPERATURE RISE:** Within NEMA MG1-22.40 definition when operating at full load.

**COOLING:** Cast centrifugal blower, direct connected.

**ELECTROMAGNETIC INTERFERENCE LEVEL:** Exceeds requirements for most marine radio-telephone equipment and standard AM televisions.

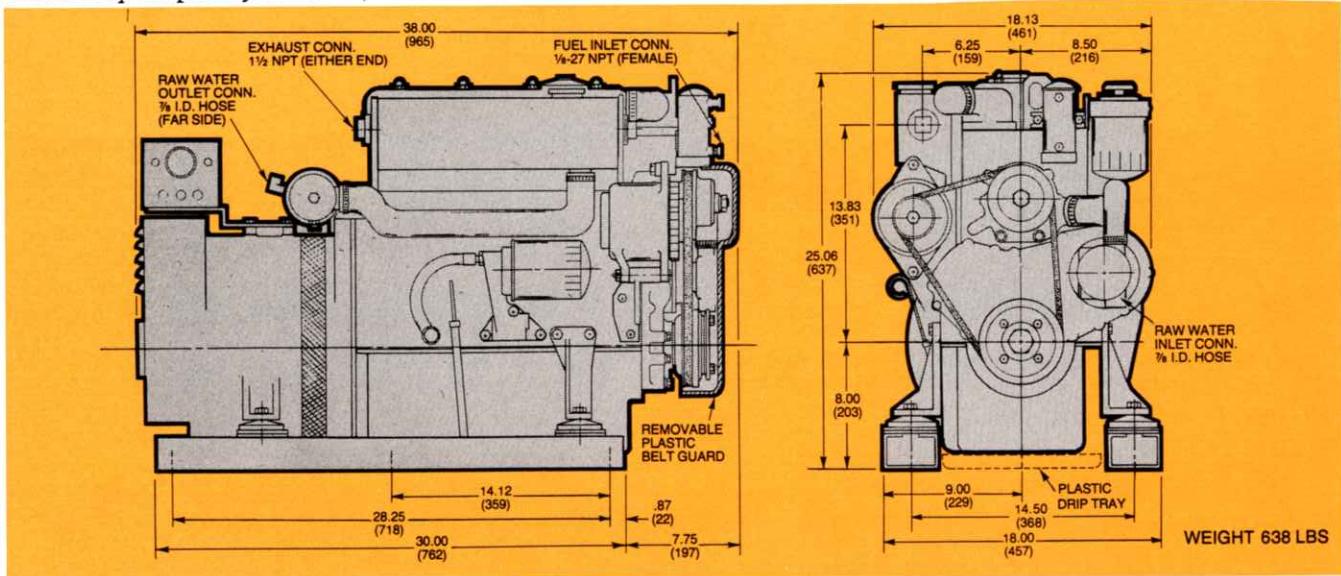

### ENGINE

Engine Type . . . 4 cycle, 4 cylinders, water cooled diesel  
 Displacement . . . . . 128 C.I.D.  
 Compression Ratio . . . . . 21:1  
 Combustion Chamber . . . . . Swirl Type  
 Injection Pump . . . . . CAV-DPA Type  
 Governor . . . . . Mechanical, built in pump, yields frequency regulation of 5%  
 Power Available . . . . . 30 HP @ 1800 RPM  
 Engine fitted and piped for self priming

### STANDARD EQUIPMENT

12 Volt 50 Ampere Alternator • Fresh Water Cooling System • Coolant Recovery Tank • Air Intake Silencer • 12 Volt Starting Motor • Vibration Isolators • Water Injected Elbow • Operators Manual • Hi Water Temp. and Lo Oil Pressure Shutdown • Hi Exhaust Temp. Shutdown.

### OPTIONAL EQUIPMENT

• Sound/Guard Enclosure • Remote Start-Stop Station • 15' Cable for Remote Panel • Ship to Shore Transfer Switch. Hydro-Hush Exhaust Silencer and Accessories.

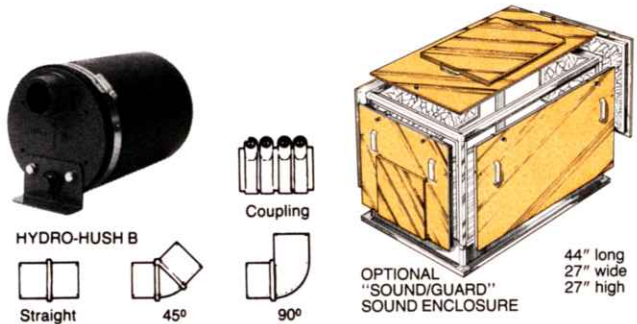

CALL YOUR WESTERBEKE REPRESENTATIVE

OR CONTACT THE . . .

